

HiKu

SUPER HIGH POWER POLY PERC MODULE

420 W ~ 435 W

CS3W-420 | 425 | 430 | 435P (IEC1000 V)

CS3W-420 | 425 | 430 | 435P (IEC1500 V)

MORE POWER



24 % more power than conventional modules



Up to 4.5 % lower LCOE
Up to 2.7 % lower system cost



Low NMOT: 42 ± 3 °C
Low temperature coefficient (Pmax):
 -0.37 % / °C



Better shading tolerance

MORE RELIABLE



Lower internal current,
lower hot spot temperature



Cell crack risk limited in small region,
enhance the module reliability



Heavy snow load up to 5400 Pa,
wind load up to 3600 Pa*



linear power output warranty*



enhanced product warranty on materials and workmanship*

*According to the applicable Canadian Solar Limited Warranty Statement.

MANAGEMENT SYSTEM CERTIFICATES*

ISO 9001:2015 / Quality management system
ISO 14001:2015 / Standards for environmental management system
OHSAS 18001:2007 / International standards for occupational health & safety

PRODUCT CERTIFICATES*

IEC 61215 / IEC 61730: VDE / CE / INMETRO
IEC 61701 ED2: VDE / IEC 62716: VDE
UL 1703: CSA
Take-e-way



* As there are different certification requirements in different markets, please contact your local Canadian Solar sales representative for the specific certificates applicable to the products in the region in which the products are to be used.

CANADIAN SOLAR INC. is committed to providing high quality solar products, solar system solutions and services to customers around the world. No. 1 module supplier for quality and performance/price ratio in IHS Module Customer Insight Survey. As a leading PV project developer and manufacturer of solar modules with over 36 GW deployed around the world since 2001.

* For detail information, please refer to Installation Manual.

CANADIAN SOLAR INC.

Canadian Solar MSS (Australia) Pty Ltd., 44 Stephenson St, Cremorne VIC 3121, Australia
support@canadiansolar.com, www.canadiansolar.com/au

ENGINEERING DRAWING (mm)

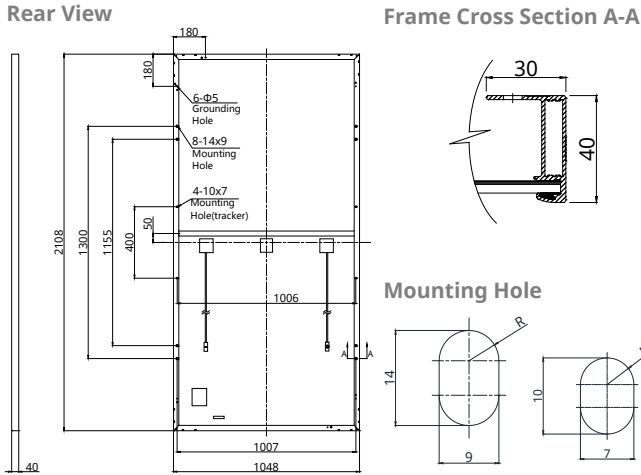

CS3W-420P / I-V CURVES

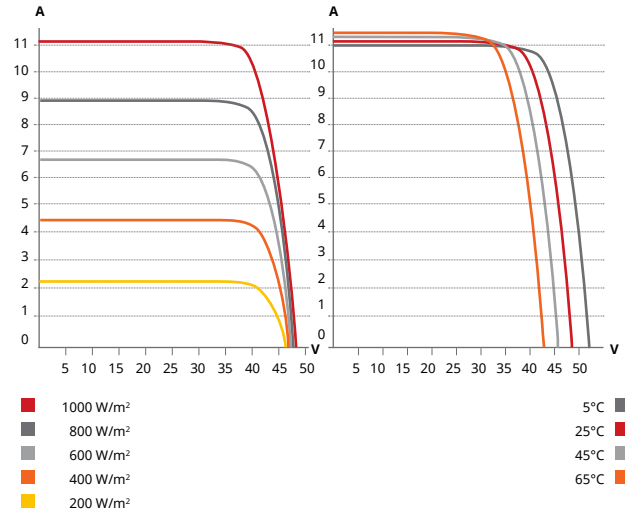

ELECTRICAL DATA | STC*

CS3W	420P	425P	430P	435P
Nominal Max. Power (P _{max})	420 W	425 W	430 W	435 W
Opt. Operating Voltage (V _{mp})	39.5 V	39.7 V	39.9 V	40.1 V
Opt. Operating Current (I _{mp})	10.64 A	10.71 A	10.78 A	10.85 A
Open Circuit Voltage (V _{oc})	48.0 V	48.2 V	48.4 V	48.6 V
Short Circuit Current (I _{sc})	11.26 A	11.29 A	11.32 A	11.35 A
Module Efficiency	19.01%	19.24%	19.46%	19.69%
Operating Temperature	-40°C ~ +85°C			
Max. System Voltage	1500V (IEC/UL) or 1000V (IEC/UL)			
Module Fire Performance	TYPE 1 (UL 1703) or CLASS C (IEC 61730)			
Max. Series Fuse Rating	20 A			
Application Classification	Class A			
Power Tolerance	0 ~ + 5 W			

* Under Standard Test Conditions (STC) of irradiance of 1000 W/m², spectrum AM 1.5 and cell temperature of 25°C. Measurement uncertainty: ±3 % (P_{max}).

ELECTRICAL DATA | NMOT*

CS3W	420P	425P	430P	435P
Nominal Max. Power (P _{max})	312 W	316 W	320 W	323 W
Opt. Operating Voltage (V _{mp})	36.7 V	36.9 V	37.1 V	37.3 V
Opt. Operating Current (I _{mp})	8.51 A	8.57 A	8.62 A	8.68 A
Open Circuit Voltage (V _{oc})	45.0 V	45.2 V	45.4 V	45.6 V
Short Circuit Current (I _{sc})	9.08 A	9.11 A	9.13 A	9.16 A

* Under Nominal Module Operating Temperature (NMOT), irradiance of 800 W/m²-spectrum AM 1.5, ambient temperature 20°C, wind speed 1 m/s.

MECHANICAL DATA

Specification	Data
Cell Type	Poly-crystalline
Cell Arrangement	144 [2 X (12 X 6)]
Dimensions	2108 X 1048 X 40 mm (83.0 X 41.3 X 1.57 in)
Weight	24.9 kg (54.9 lbs)
Front Cover	3.2 mm tempered glass
Frame	Anodized aluminium alloy, crossbar enhanced
J-Box	IP68, 3 bypass diodes
Cable	4 mm ² (IEC), 12 AWG (UL)
Cable Length (Including Connector)	Portrait: 500 mm (19.7 in) (+) / 350 mm (13.8 in) (-); landscape: 1400 mm (55.1 in); leap-frog connection: 1670 mm (65.7 in)*
Connector	T4-PC-1 (IEC 1000 V) or PV-KST4/xy-UR, PV-KBT4/xy-UR (IEC 1000 V) or T4-PPE-1 (IEC 1500 V) or PV-KST4-EVO2/XY, PV-KBT4-EVO2/XY (IEC 1500 V) or UTXC-FA4AM, UTXCMA4AM (IEC 1500 V)
Per Pallet	27 pieces
Per Container (40' HQ)	594 pieces

* For detailed information, please contact your local Canadian Solar sales and technical representatives.

TEMPERATURE CHARACTERISTICS

Specification	Data
Temperature Coefficient (P _{max})	-0.37 % / °C
Temperature Coefficient (V _{oc})	-0.29 % / °C
Temperature Coefficient (I _{sc})	0.05 % / °C
Nominal Module Operating Temperature	42 ± 3°C

PARTNER SECTION

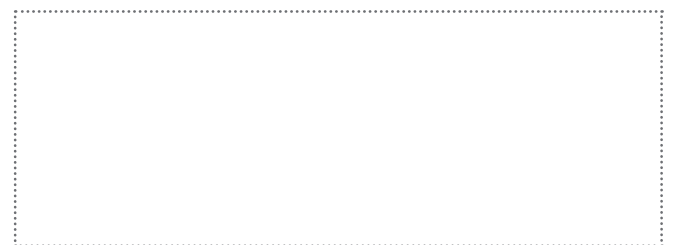

* The specifications and key features contained in this datasheet may deviate slightly from our actual products due to the on-going innovation and product enhancement. Canadian Solar Inc. reserves the right to make necessary adjustment to the information described herein at any time without further notice.

Please be kindly advised that PV modules should be handled and installed by qualified people who have professional skills and please carefully read the safety and installation instructions before using our PV modules.

CANADIAN SOLAR INC.

Canadian Solar MSS (Australia) Pty Ltd., 44 Stephenson St, Cremorne VIC 3121, Australia
support@canadiansolar.com, www.canadiansolar.com/au